

# GEAR-DRIVEN ROTORS

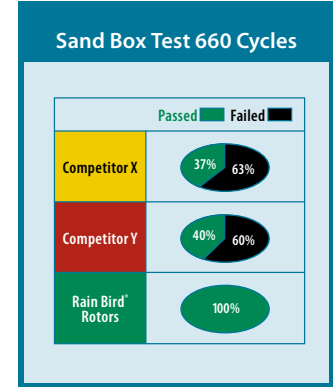

Rain Bird® Gear-Driven Rotors are engineered to efficiently manage water, while promoting a lush, highly profitable course, through minimal maintenance requirements, worry-free performance and maximum water distribution uniformity. Trusted by golf course professionals everywhere, particularly those in drought-prone areas, these innovative rotors deliver optimal playing surfaces, a smaller carbon footprint and reduced water costs.

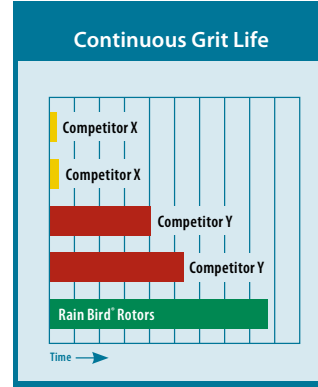

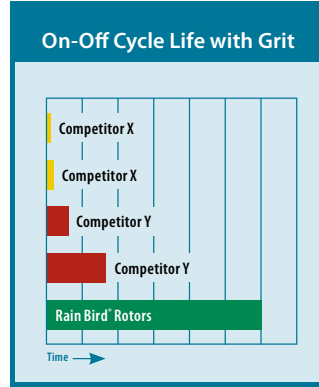
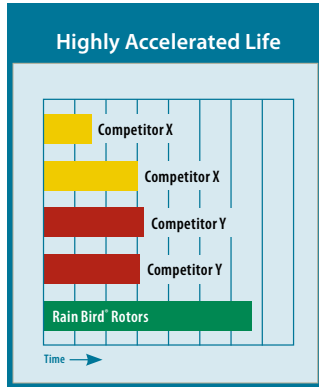

In laboratory tests, Rain Bird® Golf Rotors dramatically out-performed competitive rotors under grueling conditions.

**351B Series Short Throw** (pg 36)

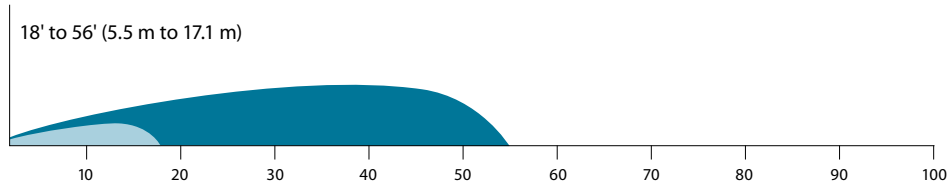

**500/550 Series** (pg 34-35)

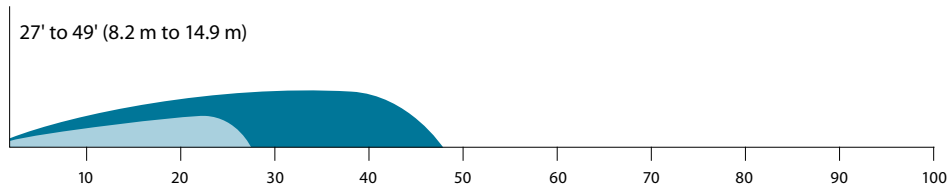

**700/751 Series** (pg 29-31) **NEW**

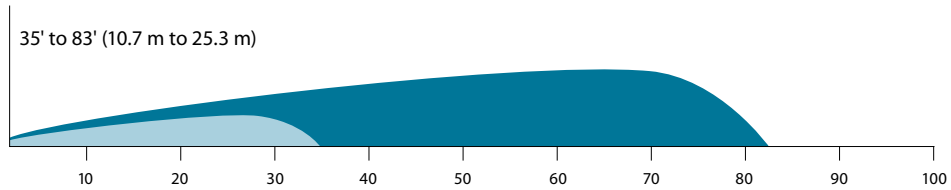

**900/950 Series** (pg 32-33)

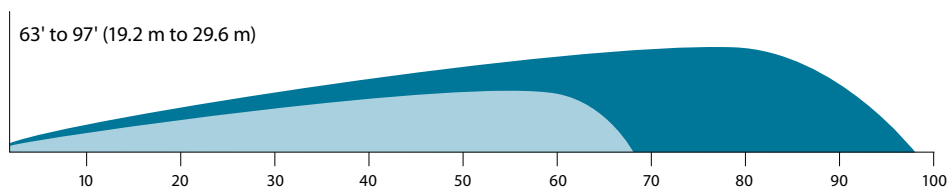

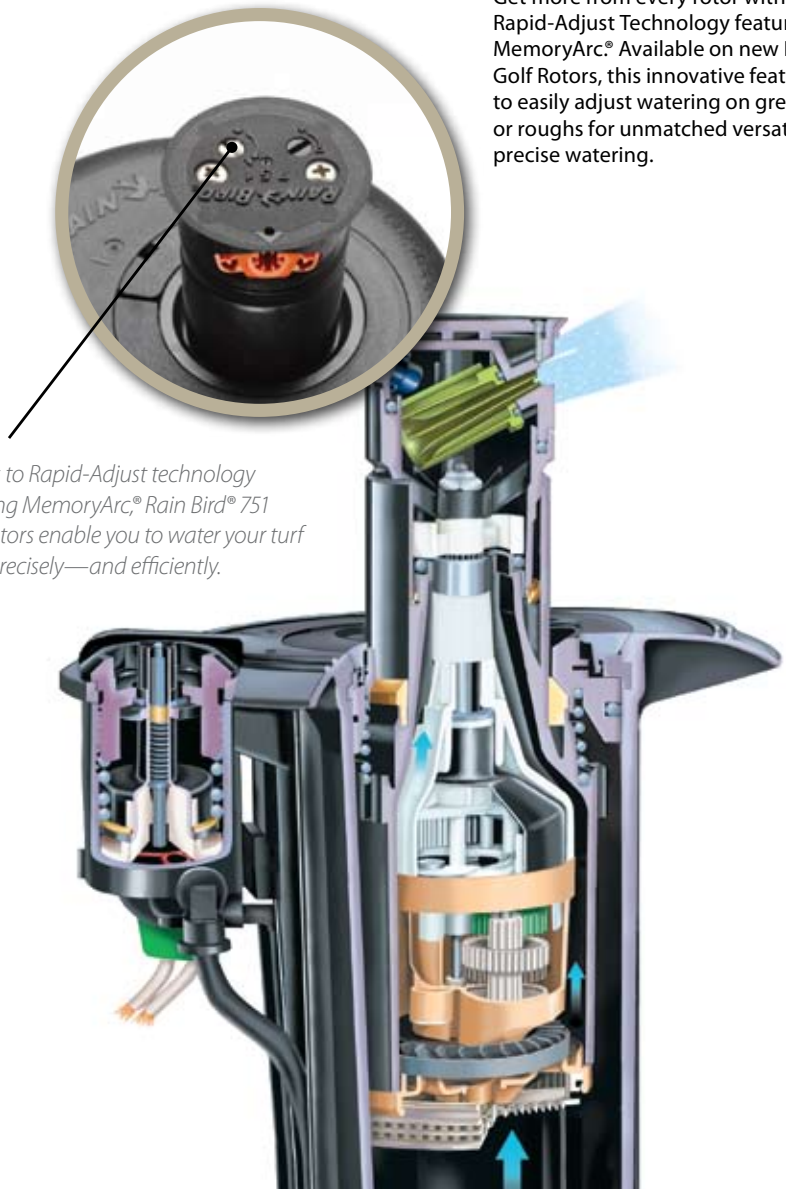

Get more from every rotor with new Rapid-Adjust Technology featuring MemoryArc.® Available on new Rain Bird® 751 Golf Rotors, this innovative feature allows you to easily adjust watering on greens, fairways or roughs for unmatched versatility and more precise watering.

Thanks to Rapid-Adjust technology featuring MemoryArc,® Rain Bird® 751 Golf Rotors enable you to water your turf more precisely—and efficiently.

**FEATURES AND BENEFITS**

**Turn-of-a-Screw Flexibility:** Unlike competitive products, Rain Bird® 751 Golf Rotors offer easy, top-adjustable rotation settings that retain the memory of their part-circle arc setting when shifting between full- and part-circle operation. This unique feature is designed to offer quick, dry arc adjustments not just during grow-in, but for the life of the rotor.

**Proven Rain Bird Performance:** Like all Rain Bird rotors, 700/751 Series Rotors are up to 23% more water-efficient than the next-closest competitor in field and lab testing. With large droplets that cut through harsh winds and consistent pressure regulation, Rain Bird rotors deliver the even distribution you need to guarantee a healthy playing surface.

**Industry-Leading Durability:** Rain Bird 700/751 Series Golf Rotors last up to 10 times longer than competitive rotors in field and lab testing. Trust their rugged construction for year after year of reliable, hassle-free performance.

**Backward Compatibility:** New Rain Bird 700/751 Series Golf Rotors offer backward compatibility with every 700 Series EAGLE™ Rotor manufactured since 1992. Saving precious time and money is as simple as dropping new Rain Bird 700/751 Series internal assemblies into your existing rotor cases.

**Lower Total Cost of Ownership:** Rain Bird Golf Rotors offer the world's lowest total cost of ownership through a powerful combination of versatility, performance and durability. Install 700 and 751 Golf Rotors to optimize water consumption, simplify operation and minimize replacement, maintenance and inventory costs.

**Introducing Rapid-Adjust Technology featuring MemoryArc®**



Set primary rotor arc.



Turn the Full/Part Adjustment Screw for full-circle operation.

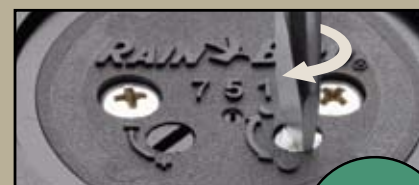

Turn to part circle again for either Arc A or Arc B setting.

No need to adjust arc when going between full- and part-circle settings.

**Versatility with a twist.** Easily shift between three arc settings to selectively water fairways, roughs—or both.

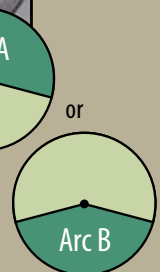

## SPECIFICATIONS

### Radius:

**Rain Bird® 700 Series:** 56' to 79' (17.1 m to 24.1 m)  
**Rain Bird® 751 Series:** 35' to 75' (10.7 m to 22.9 m)

### Flow Rate:

**700 Series:** 16.3 to 43.9 gpm (1.03 to 2.76 l/s)  
(3.70 to 9.95 m<sup>3</sup>/h)  
**751 Series:** 7.0 to 37.7 gpm (0.44 to 2.38 l/s)  
(1.59 to 8.56 m<sup>3</sup>/h)

### Arc:

**700 Series:** Full-circle 360°  
**751 Series:** Full-circle 360°; Adjustable 30° to 345°

### Models:

#### Full-Circle:

- ✓ **700E:** Electric
- ✓ **700IC:** Integrated Control
- 700S/H:** Combined use Stopmatic (SAM) or Hydraulic (N.O.)\*
- 700B:** Seal-A-Matic™ device

#### Part-Circle:

- ✓ **751E:** Electric
- ✓ **751IC:** Integrated Control
- 751S/H:** Combined use Stopmatic (SAM) or Hydraulic (N.O.)\*
- 751B:** Seal-A-Matic™ device

### Maximum Inlet Pressure:

**Models 700/751E and IC:** 150 psi (10.3 bars)  
**Models 700/751S/H and B:** 100 psi (6.9 bars)

**Pressure Regulation Range:** 60 to 100 psi  
(4.1 to 6.9 bars)

**Factory Pressure Settings:** 700E/IC and 751E/IC available in 60, 70 and 80 psi (4.1, 4.8 and 5.5 bars)

### Dimensions:

#### Body Height:

**Models E, IC, S/H:** 12.0" (30.5 cm)  
**Models B:** 9.6" (24.5 cm)

#### Pop-Up Height to Mid-Nozzle:

**Models E, IC, S/H, B:** 2.6" (6.6 cm)

#### Top Diameter:

**Models E, IC, S/H:** 6.25" (15.9 cm)  
**Models B:** 4.25" (10.8 cm)

### Rotation Time:

**700 Series:** 360° in ≤ 180 seconds;  
150 seconds nominally  
**751 Series:** 180° in ≤ 90 seconds;  
75 seconds nominally

### Inlet Threads:

**Models E, IC, S/H:** 1.25" (3.2 cm) ACME  
Female Threaded  
**Models B:** 1" (2.5 cm) ACME Female Threaded

### Holdback:

**Block:** 10' (3.1 m) of elevation  
**SAM/Hydraulic:** 15' (4.6 m) of elevation

### Nozzle Trajectory:

25°

### Maximum Stream Height:

17' (5.2 m)

**Solenoid:** 24 VAC solenoid power requirement: 0.41 amp inrush current (9.8 VA); **60 cycle:** 0.25 amp holding current (6.0 VA); **50 cycle:** 0.32 amp holding current (7.7 VA)

**Surge Resistance:** Up to 20KV standard on electric models

✓ **Top-Serviceable Rock Screen™ and Replaceable Valve Seat:** On models 700E, IC, S/H and 751E, IC, S/H

\*N.O. — Normally open

All data is generated from tests conducted in accordance with ASAE Standard S398.1 for at least 30 minutes in zero-wind conditions. Rain Bird recommends the use of SPACE for Windows®, equivalent program or derived performance data to optimize nozzle selection.



## 700 Series

### HOW TO SPECIFY

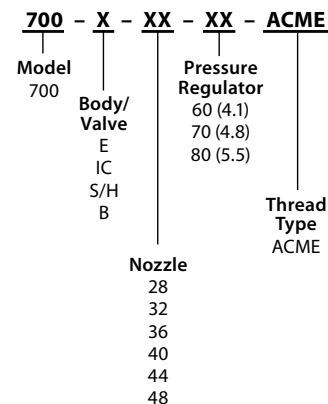

## 751 Series

### HOW TO SPECIFY

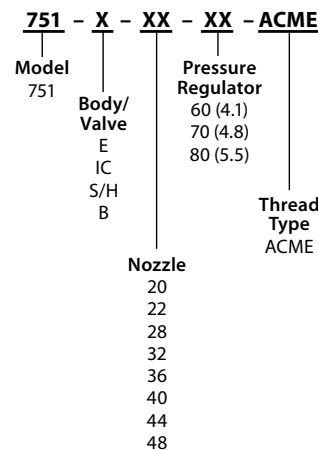



700 SERIES PERFORMANCE DATA — U.S.												
Base Pressure (psi)	50		60		70		80		90		100	
	Radius (ft)	Flow (gpm)	Radius (ft)	Flow (gpm)	Radius (ft)	Flow (gpm)	Radius (ft)	Flow (gpm)	Radius (ft)	Flow (gpm)	Radius (ft)	Flow (gpm)
<b>WIND TOLERANT NOZZLES</b>												
#16 - Gray	-	-	56	16.3	56	17.5	60	18.5	62	20.2	63	21.1
#18 - Red	-	-	58	19.0	61	20.9	65	22.3	65	23.2	65	24.2
#22 - Black	-	-	-	-	65	27.6	65	34.8	67	38.8	71	40.5
<b>DUAL SPREADER™ NOZZLES</b>												
#28 - White	59	20.0	57	21.9	57	23.7	61	22.8	61	24.1	61	25.5
#32 - Blue	61	21.9	63	22.8	65	24.5	65	27.4	67	29	67	29.6
#36 - Yellow	65	23.2	65	25.5	65	27.5	67	29.5	65	31.2	67	32.9
#40 - Orange	65	25.5	67	27.8	71	29.8	71	31.9	73	33.9	73	35.6
#44 - Green	-	-	71	30.7	69	33.0	71	35.2	75	37.5	75	39.5
#48 - Black	-	-	-	-	73	37.0	77	39.4	79	41.8	77	43.8

751 SERIES PERFORMANCE DATA — U.S.												
Base Pressure (psi)	50		60		70		80		90		100	
	Radius (ft)	Flow (gpm)	Radius (ft)	Flow (gpm)	Radius (ft)	Flow (gpm)	Radius (ft)	Flow (gpm)	Radius (ft)	Flow (gpm)	Radius (ft)	Flow (gpm)
<b>WIND TOLERANT NOZZLES</b>												
#16 WTN - Gray	-	-	60	15.7	62	16.7	62	17.8	64	18.8	66	20.4
#18 WTN - Red	-	-	63	18.8	63	20.0	65	21.4	67	22.7	67	24.0
#22 WTN - Black	-	-	-	-	65	27.6	65	35.8	67	37.6	71	41.1
<b>DUAL SPREADER™ NOZZLES</b>												
#20 - Gray	35	7.0	35	7.6	37	8.1	39	8.6	-	-	-	-
#22 - Red	40	8.3	45	9.5	45	10.2	43	10.8	-	-	-	-
#28 - White	55	15.2	57	16.8	59	18.1	59	19.3	59	20.5	57	21.5
#32 - Blue	59	17.1	61	18.6	61	20	61	21.4	63	22.5	63	23.9
#36 - Yellow	61	19.1	63	20.8	65	22.6	67	24	69	25.5	69	26.5
#40 - Orange	63	21.7	67	23.8	69	28.3	71	30.4	71	28.9	71	30.7
#44 - Green	-	-	65	26.3	69	28.3	71	30.4	71	32.1	73	34.1
#48 - Black	-	-	-	-	69	31.4	73	33.7	75	35.7	73	37.7

700 SERIES PERFORMANCE DATA — METRIC																		
Base Pressure (bars)	3.4			4.1			4.8			5.5			6.2			6.9		
	Radius (m)	Flow (l/s)	Flow (m³/h)	Radius (m)	Flow (l/s)	Flow (m³/h)	Radius (m)	Flow (l/s)	Flow (m³/h)	Radius (m)	Flow (l/s)	Flow (m³/h)	Radius (m)	Flow (l/s)	Flow (m³/h)	Radius (m)	Flow (l/s)	Flow (m³/h)
<b>WIND TOLERANT NOZZLES</b>																		
#16 - Gray	-	-	-	17.1	1.03	3.70	17.1	1.10	3.97	18.3	1.17	4.20	18.9	1.27	4.59	19.2	1.33	4.79
#18 - Red	-	-	-	17.7	1.20	4.32	18.6	1.32	4.75	19.8	1.41	5.06	19.8	1.46	5.27	19.8	1.53	5.50
#22 - Black	-	-	-	-	-	-	19.8	1.74	6.27	19.8	2.20	7.90	20.4	2.45	8.81	21.6	2.56	9.20
<b>DUAL SPREADER™ NOZZLES</b>																		
#28 - White	18.0	1.26	4.54	17.4	1.38	4.97	17.4	1.50	5.38	18.6	1.44	5.18	18.6	1.52	5.47	18.6	1.61	5.79
#32 - Blue	18.6	1.38	4.97	19.2	1.44	5.18	19.8	1.55	5.56	19.8	1.73	6.22	20.4	1.83	6.59	20.4	1.87	6.72
#36 - Yellow	19.8	1.46	5.27	19.8	1.61	5.79	19.8	1.73	6.25	20.4	1.86	6.70	19.8	1.97	7.09	20.4	2.08	7.47
#40 - Orange	19.8	1.61	5.79	20.4	1.75	6.31	21.6	1.88	6.77	21.6	2.01	7.25	22.3	2.14	7.70	22.3	2.25	8.09
#44 - Green	-	-	-	21.6	1.94	6.97	21.0	2.08	7.49	21.6	2.22	7.99	22.9	2.37	8.52	22.9	2.49	8.97
#48 - Black	-	-	-	-	-	-	22.3	2.33	8.40	23.5	2.49	8.95	24.1	2.64	9.49	23.5	2.76	9.95

751 SERIES PERFORMANCE DATA — METRIC																		
Base Pressure (bars)	3.4			4.1			4.8			5.5			6.2			6.9		
	Radius (m)	Flow (l/s)	Flow (m³/h)	Radius (m)	Flow (l/s)	Flow (m³/h)	Radius (m)	Flow (l/s)	Flow (m³/h)	Radius (m)	Flow (l/s)	Flow (m³/h)	Radius (m)	Flow (l/s)	Flow (m³/h)	Radius (m)	Flow (l/s)	Flow (m³/h)
<b>WIND TOLERANT NOZZLES</b>																		
#16 WTN - Gray	-	-	-	18.3	0.99	3.57	18.9	1.05	3.79	18.9	1.12	4.04	19.5	1.19	4.27	20.1	1.29	4.63
#18 WTN - Red	-	-	-	19.2	1.19	4.27	19.2	1.26	4.54	19.8	1.35	4.86	20.4	1.43	5.16	20.4	1.51	5.45
#22 WTN - Black	-	-	-	-	-	-	19.8	1.74	6.27	19.8	2.26	8.13	20.4	2.37	8.54	21.6	2.59	9.33
<b>DUAL SPREADER™ NOZZLES</b>																		
#20 - Gray	10.7	0.44	1.59	10.7	0.48	1.73	11.3	0.51	1.84	11.9	0.54	1.95	-	-	-	-	-	-
#22 - Red	12.2	0.52	1.89	13.7	0.60	2.16	13.7	0.64	2.32	13.1	0.68	2.45	-	-	-	-	-	-
#28 - White	16.8	0.96	3.45	17.4	1.06	3.82	18.0	1.14	4.11	18.0	1.22	4.38	18.0	1.29	4.66	17.4	1.36	4.88
#32 - Blue	18.0	1.08	3.88	18.6	1.17	4.22	18.6	1.26	4.54	18.6	1.35	4.86	19.2	1.42	5.11	19.2	1.51	5.43
#36 - Yellow	18.6	1.21	4.34	19.2	1.31	4.72	19.8	1.43	5.13	20.4	1.51	5.45	21.0	1.61	5.79	21.0	1.67	6.02
#40 - Orange	19.2	1.37	4.93	20.4	1.50	5.41	21.0	1.62	5.81	21.0	1.73	6.25	21.6	1.82	6.56	21.6	1.94	6.97
#44 - Green	-	-	-	19.8	1.66	5.97	21.0	1.79	6.43	21.6	1.92	6.90	21.6	2.03	7.29	22.3	2.15	7.74
#48 - Black	-	-	-	-	-	-	21.0	1.98	7.13	22.3	2.13	7.65	22.9	2.25	8.11	22.3	2.38	8.56

All data reflects no pressure regulation.

### SPECIFICATIONS

#### Radius:

**EAGLE 900 Series:** 63' to 97' (19.2 m to 29.6 m)  
**EAGLE 950 Series:** 70' to 92' (21.3 m to 28.0 m)

#### Flow Rate:

**EAGLE 900 Series:** 21.4 to 57.1 gpm  
 (1.35 to 3.60 l/s) (4.85 to 12.97 m<sup>3</sup>/h)  
**EAGLE 950 Series:** 19.5 to 59.4 gpm  
 (1.23 to 3.75 l/s) (4.43 to 13.49 m<sup>3</sup>)

#### Arc:

**EAGLE 900 Series:** Full-circle, 360°  
**EAGLE 950 Series:** 40° to 345°

#### Models:

##### Full-Circle:

- ✓ **EAGLE 900E:** Electric
- ✓ **EAGLE 900 IC:** Integrated Control
- EAGLE 900S/H:** Combined use Stopmatic (SAM) or Hydraulic (N.O.)\*

##### Part-Circle:

- ✓ **EAGLE 950E:** Electric
- ✓ **EAGLE 950 IC:** Integrated Control
- EAGLE 950S/H:** Combined use Stopmatic (SAM) or Hydraulic (N.O.)\*

#### Maximum Inlet Pressure:

**Models 900E/IC, 950E/IC:** 150 psi (10.3 bars)  
**Models 900S/H, 950S/H:** 100 psi (6.9 bars)

#### Pressure Regulation Range:

60 to 100 psi (4.1 to 6.9 bars)

#### Factory Pressure Settings:

900E/IC and 950E/IC available in 70 and 80 psi  
 (4.8 and 5.5 bars)

#### Dimensions:

**Body Height:** 13.4" (34.0 cm)  
**Pop-Up Height to Mid-Nozzle:** 2.25" (5.7 cm)  
**Top Diameter:** 7" (17.8 cm)

#### Nozzle Trajectory:

25°

#### Inlet Threads:

1.5" (3.8 cm) (15/21) ACME  
 Female Threaded

#### Holdback:

SAM/Hydrologic 15' (4.6 m) elevation

#### Rotation Time:

**900 Series:** 360° in ≤ 240 seconds;  
 210 seconds nominally  
**950 Series:** 180° in ≤ 120 seconds;  
 105 seconds nominally

#### Maximum Stream Height:

20' (6.1 m)

#### Solenoid:

24 VAC solenoid power requirement:  
 0.41 amp inrush current (9.8 VA); **60 cycle:** 0.25 amp  
 holding current (6.0 VA); **50 cycle:** 0.32 amp holding  
 current (7.7 VA).

#### Surge Resistance:

Up to 20KV standard on  
 electric models



**Top-Serviceable Rock Screen™ and  
 Replaceable Valve Seat:** All 900 and 950 models

*All data is generated from tests conducted in accordance with ASAE Standard S398.1 for at least 30 minutes in zero-wind conditions. Rain Bird recommends the use of SPACE for Windows®, equivalent program or derived performance data to optimize nozzle selection.*

\* N.O. — Normally open



### ● EAGLE™ 900 Series

#### HOW TO SPECIFY

<b>900</b>	-	<b>X</b>	-	<b>XX</b>	-	<b>XX</b>	-	<b>ACME</b>
Model		Body/ Valve		Pressure Regulator				Thread Type
900		E IC S/H		70 (4.8) 80 (5.5)				ACME
				Nozzle				
				44				
				48				
				52				
				56				
				60				
				64				



### ● EAGLE™ 950 Series

#### HOW TO SPECIFY

<b>950</b>	-	<b>X</b>	-	<b>XX</b>	-	<b>XX</b>	-	<b>ACME</b>
Model		Body/ Valve		Pressure Regulator				Thread Type
950		E IC S/H		60 (4.1) 70 (4.8) 80 (5.5)				ACME
				Nozzle				
				18				
				20				
				22				
				24				
				26				
				28				
				30				
				32				



### EAGLE 900 SERIES PERFORMANCE DATA — U.S.

HIGH PERFORMANCE NOZZLES												
Base Pressure (psi)	#44 BLUE		#48 YELLOW		#52 ORANGE		#56 GREEN		#60 BLACK		#64 RED	
	Radius (ft)	Flow (gpm)	Radius (ft)	Flow (gpm)	Radius (ft)	Flow (gpm)	Radius (ft)	Flow (gpm)	Radius (ft)	Flow (gpm)	Radius (ft)	Flow (gpm)
60	63	21.4	73	28.9	75	31.9	—	—	—	—	—	—
70	67	23.5	73	31.9	79	34.6	83	40.7	87	43.2	91	47.2
80	71	24.7	75	34.1	81	37.1	85	43.5	91	49.5	93	51.0
90	71	26.5	77	35.0	81	39.5	87	46.4	91	49.5	95	54.0
100	73	27.9	77	36.2	83	41.8	89	49.1	91	52.2	97	57.1

### EAGLE 950 SERIES PERFORMANCE DATA — U.S.

NOZZLES																
Base Pressure (psi)	#18 WHITE-C		#20 GRAY-C		#22 BLUE-C		#24 YELLOW-C		#26 ORANGE		#28 GREEN		#30 BLACK		#32 BROWN	
	Radius (ft)	Flow (gpm)	Radius (ft)	Flow (gpm)	Radius (ft)	Flow (gpm)	Radius (ft)	Flow (gpm)	Radius (ft)	Flow (gpm)	Radius (ft)	Flow (gpm)	Radius (ft)	Flow (gpm)	Radius (ft)	Flow (gpm)
60	70	19.5	72	23.0	74	26.5	76	30.8	78	36.0	—	—	—	—	—	—
70	72	21.3	74	25.1	76	28.8	80	33.5	82	38.7	84	42.9	84	47.3	84	50.4
80	74	22.9	76	27.0	80	30.9	84	36.0	84	41.5	86	47.3	86	50.4	85	53.1
90	75	24.4	78	28.7	82	32.9	88	38.4	86	43.4	89	48.5	90	52.9	88	55.6
100	76	25.8	80	30.5	84	34.6	90	40.5	88	46.7	91	52.2	92	55.8	92	59.4

### EAGLE 900 SERIES PERFORMANCE DATA — METRIC

HIGH PERFORMANCE NOZZLES																		
Base Pressure (bars)	#44 BLUE			#48 YELLOW			#52 ORANGE			#56 GREEN			#60 BLACK			#64 RED		
	Radius (m)	Flow (l/s)	Flow (m³/h)	Radius (m)	Flow (l/s)	Flow (m³/h)	Radius (m)	Flow (l/s)	Flow (m³/h)	Radius (m)	Flow (l/s)	Flow (m³/h)	Radius (m)	Flow (l/s)	Flow (m³/h)	Radius (m)	Flow (l/s)	Flow (m³/h)
4.1	19.2	1.35	4.85	22.3	1.82	6.56	22.9	2.01	7.25	—	—	—	—	—	—	—	—	—
4.5	19.8	1.42	5.11	22.3	1.89	6.81	23.5	2.10	7.57	25.0	2.48	8.94	26.2	2.63	9.47	27.4	2.88	10.35
5.0	20.7	1.50	5.40	22.4	2.00	7.22	24.2	2.22	8.00	25.5	2.61	9.40	26.8	2.78	10.00	27.9	3.04	10.94
5.5	21.6	1.55	5.59	22.8	2.14	7.72	24.7	2.34	8.41	25.9	2.74	9.87	27.7	2.92	10.52	28.3	3.21	11.56
6.0	21.6	1.64	5.90	23.3	2.19	7.88	24.7	2.45	8.81	26.3	2.87	10.34	27.7	3.20	11.86	28.8	3.35	12.06
6.5	21.9	1.71	6.16	23.5	2.24	8.06	24.9	2.55	9.19	26.8	3.00	10.80	27.7	3.20	11.86	29.2	3.49	12.57
6.9	22.3	1.76	6.35	23.5	2.28	8.22	25.3	2.64	9.49	27.1	3.10	11.15	27.7	3.29	11.86	29.6	3.60	12.97

### EAGLE 950 SERIES PERFORMANCE DATA — METRIC

NOZZLES																									
Base Pressure (bars)	#18 WHITE-C			#20 GRAY-C			#22 BLUE-C			#24 YELLOW-C			#26 ORANGE			#28 GREEN			#30 BLACK			#32 BROWN			
	Radius (m)	Flow (l/s)	Flow (m³/h)	Radius (m)	Flow (l/s)	Flow (m³/h)	Radius (m)	Flow (l/s)	Flow (m³/h)	Radius (m)	Flow (l/s)	Flow (m³/h)	Radius (m)	Flow (l/s)	Flow (m³/h)	Radius (m)	Flow (l/s)	Flow (m³/h)	Radius (m)	Flow (l/s)	Flow (m³/h)	Radius (m)	Flow (l/s)	Flow (m³/h)	
4.1	21.3	1.23	4.43	21.9	1.45	5.22	22.6	1.67	6.02	23.2	1.94	7.00	23.8	2.27	8.18	—	—	—	—	—	—	—	—	—	—
4.5	21.7	1.29	4.64	22.3	1.52	5.48	22.9	1.75	6.29	23.8	2.03	7.32	24.4	2.36	8.50	25.2	2.62	9.44	25.2	2.90	—	25.3	3.10	11.17	
5.0	22.1	1.37	4.93	22.7	1.61	5.81	23.5	1.85	6.66	24.7	2.15	7.75	25.1	2.49	8.95	25.8	2.78	10.00	25.8	3.03	10.92	25.7	3.22	11.60	
5.5	22.5	1.44	5.19	23.2	1.70	6.12	24.4	1.95	7.01	25.6	2.27	8.16	25.6	2.61	9.41	26.2	2.98	10.72	26.2	3.18	11.43	25.9	3.35	12.05	
6.0	22.8	1.51	5.44	23.6	1.78	6.40	24.8	2.04	7.34	26.5	2.38	8.56	26.0	2.70	9.73	26.9	3.04	10.93	27.1	3.29	11.85	26.6	3.46	12.46	
6.5	23.0	1.58	5.68	24.0	1.86	6.69	25.3	2.12	7.64	27.1	2.48	8.93	26.5	2.83	10.18	27.4	3.16	11.37	27.7	3.42	12.30	27.3	3.61	13.00	
6.9	23.2	1.63	5.86	24.4	1.92	6.93	25.6	2.18	7.86	27.4	2.56	9.20	26.8	2.95	10.61	27.7	3.29	11.86	28.0	3.52	12.67	28.0	3.75	13.49	

### SPECIFICATIONS

#### Radius:

EAGLE 500 Series: 33' to 47' (10.1 m to 14.3 m)  
EAGLE 550 Series: 33' to 49' (10.3 m to 14.9 m)

#### Flow Rate:

EAGLE 500 Series: 6.0 to 13.2 gpm (0.38 to 0.83 l/s)  
(1.36 to 3.00 m<sup>3</sup>/h)  
EAGLE 550 Series: 6.0 to 13.6 gpm (0.38 to 0.86 l/s)  
(1.36 to 3.09 m<sup>3</sup>/h)

#### Arc:

EAGLE 500 Series: Full-circle, 360°  
EAGLE 550 Series: Adjustable 30° to 345°

#### Models:

##### Full-Circle:

- EAGLE 500E: Fast rotation, electric
- ✓ EAGLE 500 IC: Integrated Control
- EAGLE 500S/H: Fast rotation, combined use  
Stopmatic (SAM) or Hydraulic (N.O.)\*

##### Part-Circle:

- EAGLE 550E: Fast rotation, electric
- ✓ EAGLE 550 IC: Integrated Control
- EAGLE 550S/H: Fast rotation, combined use  
Stopmatic (SAM) or Hydraulic (N.O.)\*

#### Maximum Inlet Pressure:

Models 500E/IC, 550E/IC: 150 psi (10.3 bars)  
Models 500S/H, 550S/H: 100 psi (6.9 bars)

#### Pressure Regulation Range: 60 to 100 psi (4.1 to 6.9 bars)

#### Factory Pressure Settings: 500E/IC and 550E/IC available in 60, 70 and 80 psi (4.1, 4.8 and 5.5 bars)

#### Dimensions:

Body Height: 12.0" (30.5 cm)  
Pop-Up Height to Mid-Nozzle: 2.6" (6.6 cm)  
Top Diameter: 6.25" (15.9 cm)

#### Nozzle Trajectory: 25°

#### Inlet Threads: 1.25" (3.2 cm) (33/42) ACME

#### Holdback: SAM/Hydrologic 15' (4.6 m) elevation

#### Rotation Time:

500 Series: 360° in ≤ 120 seconds;  
90 seconds nominally  
550 Series: 180° in ≤ 60 seconds;  
45 seconds nominally

#### Maximum Stream Height: 13' (4.0 m)

#### Solenoid: 24 VAC solenoid power requirement: 0.41 amp inrush current (9.8 VA); 60 cycle: 0.25 amp holding current (6.0 VA); 50 cycle: 0.32 amp holding current (7.7 VA)

#### Surge Resistance: Up to 20KV standard on electric models

- ✓ Top-Serviceable Rock Screen™ and  
Replaceable Valve Seat: On models 500E, 550E,  
500H, 550H

*All data is generated from tests conducted in accordance with ASAE Standard S398.1 for at least 30 minutes in zero-wind conditions. Rain Bird recommends the use of SPACE for Windows®, equivalent program or derived performance data to optimize nozzle selection.*

\*N.O.—Normally open



### ● EAGLE™ 500 Series

#### HOW TO SPECIFY

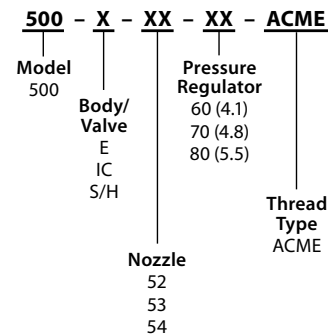

### ● EAGLE™ 550 Series

#### HOW TO SPECIFY

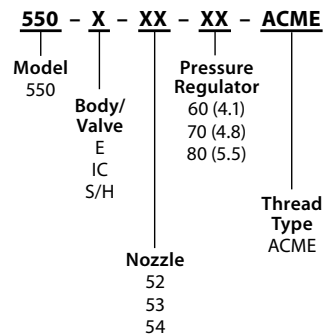

### EAGLE 500 SERIES PERFORMANCE DATA — U.S.

**NOZZLES**

Base Pressure (psi)	#52 BEIGE		#53 GRAY		#54 RED	
	Radius (ft)	Flow (gpm)	Radius (ft)	Flow (gpm)	Radius (ft)	Flow (gpm)
40	33	6.0	41	7.7	45	9.3
50	35	6.6	43	8.6	47	10.3
60	35	7.2	43	9.4	47	11.2
70	35	7.7	45	10.1	47	12.0
80	35	8.3	45	10.8	47	12.8
90	37	8.7	43	10.9	47	12.8
100	35	9.1	43	11.2	47	13.2

### EAGLE 550 SERIES PERFORMANCE DATA — U.S.

**NOZZLES**

Base Pressure (psi)	#52 BEIGE		#53 GRAY		#54 RED	
	Radius (ft)	Flow (gpm)	Radius (ft)	Flow (gpm)	Radius (ft)	Flow (gpm)
40	33	6.0	41	7.7	45	9.3
50	35	6.6	41	8.6	47	10.3
60	35	7.2	43	9.4	49	11.2
70	35	7.7	43	10.1	49	12.0
80	37	8.3	43	10.8	49	12.8
90	39	8.8	43	11.5	49	12.9
100	39	9.1	45	12.0	49	13.6

### EAGLE 500 SERIES PERFORMANCE DATA — METRIC

**NOZZLES**

Base Pressure (bars)	#52 BEIGE			#53 GRAY			#54 RED		
	Radius (m)	Flow (l/s)	Flow (m³/h)	Radius (m)	Flow (l/s)	Flow (m³/h)	Radius (m)	Flow (l/s)	Flow (m³/h)
2.8	10.1	3.8	1.36	12.5	0.49	1.75	13.7	0.59	2.11
3.0	10.3	0.39	1.41	12.7	0.51	1.82	13.9	0.61	2.19
3.5	10.7	0.42	1.51	13.1	0.55	1.97	14.3	0.65	2.36
4.0	10.7	0.45	1.61	13.1	0.58	2.10	14.3	0.70	2.50
4.5	10.7	0.47	1.70	13.4	0.62	2.22	14.3	0.73	2.64
5.0	10.7	0.50	1.78	13.7	0.65	2.33	14.3	0.77	2.77
5.5	10.7	0.52	1.88	13.7	0.68	2.45	14.3	0.81	2.91
6.0	11.1	0.54	1.95	13.3	0.69	2.47	14.3	0.81	2.91
6.5	11.0	0.56	2.01	13.1	0.70	2.50	14.3	0.82	2.95
6.9	10.7	0.57	2.07	13.3	0.71	2.54	14.3	0.83	3.00

### EAGLE 550 SERIES PERFORMANCE DATA — METRIC

**NOZZLES**

Base Pressure (bars)	#52 BEIGE			#53 GRAY			#54 RED		
	Radius (m)	Flow (l/s)	Flow (m³/h)	Radius (m)	Flow (l/s)	Flow (m³/h)	Radius (m)	Flow (l/s)	Flow (m³/h)
2.8	10.1	0.38	1.36	12.5	0.49	1.75	13.7	0.59	2.11
3.0	10.3	0.39	1.41	12.5	0.51	1.82	13.9	0.61	2.19
3.5	10.7	0.42	1.51	12.5	0.55	1.97	14.4	0.65	2.36
4.0	10.7	0.45	1.61	12.9	0.58	2.10	14.8	0.70	2.50
4.5	10.7	0.47	1.70	13.1	0.62	2.22	14.9	0.73	2.64
5.0	10.8	0.50	1.78	13.1	0.65	2.33	14.9	0.77	2.77
5.5	11.3	0.52	1.88	13.1	0.68	2.45	14.9	0.81	2.91
6.0	11.7	0.55	1.96	13.1	0.71	2.56	14.9	0.81	2.92
6.5	11.9	0.56	2.03	13.4	0.74	2.66	14.9	0.83	3.00
6.9	11.9	0.57	2.07	13.7	0.76	2.73	14.9	0.86	3.09

### SPECIFICATIONS

**Radius:** 18' to 56' (5.5 m to 17.1 m)

**Arc:** 360° in full-circle mode, adjustable from 50° to 330° in part-circle mode

**Flow Rate:** 1.8 to 15.5 gpm (0.11 to 0.98 l/s)

**Models:**

EAGLE™ 351B: SEAL-A-MATIC™ device

**Maximum Inlet Pressure:** 100 psi (6.9 bar)

**Recommended Operating Pressure:** 60 psi (4.1 bar), 70 psi (4.8 bar), 80 psi (5.5 bar)

**Flow:**

**Full-Circle Mode:** 360° ≤ 180 seconds; 120 seconds nominally

**Part-Circle Mode:** 180° ≤ 90 seconds; 60 seconds nominally

**Inlet Threads:** 1" (2.5 cm) ACME

**Holdback:** 10' (3.1 m) of elevation

**Nozzle Trajectory:** 17° and 25°

**Maximum Stream Height:** 13' (4.0 m)

**Dimensions:**

**Body Height:** 9.6" (24.5 cm)

**Top Diameter:** 4.25" (10.8 cm)

**Pop-Up Height to Mid-Nozzle:** 3.25" (8.3 cm)



● EAGLE™ 351B Series

### HOW TO SPECIFY

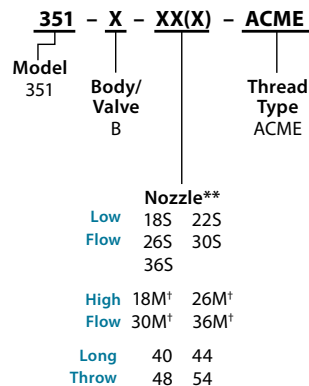

### EAGLE 351B SERIES PERFORMANCE DATA — U.S.

BASE PRESSURE		60 PSI		70 PSI		80 PSI		90 PSI	
Nozzle		Radius (ft)	Flow (gpm)	Radius (ft)	Flow (gpm)	Radius (ft)	Flow (gpm)	Radius (ft)	Flow (gpm)
LOW FLOW	18S White	18	1.8	20	1.9	20	2.0	22	2.2
	22S Dark Gray	22	2.2	22	2.4	24	2.5	26	2.7
	26S Dark Orange	24	2.6	24	2.8	26	3.1	26	3.2
	30S Light Green	30	3.0	30	3.1	32	3.2	32	3.4
	36S Brown	34	3.6	34	3.8	34	4.2	36	4.4
HIGH FLOW	18M Ivory	20	4.0	22	4.2	22	4.4	24	4.7
	26M Medium Orange	24	5.6	24	6.0	26	6.5	26	6.9
	30M Green	30	5.7	30	6.2	32	6.6	32	7.1
	36M Light Brown	34	7.1	34	7.8	34	8.4	36	8.9
LONG THROW	40 Orange	40	2.1	40	2.3	42	2.4	42	2.5
	44 Red	44	3.5	46	3.6	46	4.1	46	4.3
	48 Blue	48	5.8	48	6.4	48	6.8	48	7.0
	54 Beige	50*	12.4*	54*	13.5*	56*	14.6*	56*	15.5*

### EAGLE 351B SERIES PERFORMANCE DATA — METRIC

BASE PRESSURE		4.1 BAR			4.8 BAR			5.5 BAR			6.2 BAR		
Nozzle		Radius (m)	Flow (lps)	Flow (m³/h)	Radius (m)	Flow (lps)	Flow (m³/h)	Radius (m)	Flow (lps)	Flow (m³/h)	Radius (m)	Flow (lps)	Flow (m³/h)
LOW FLOW	18S White	5.5	0.11	0.41	6.1	0.12	0.43	6.1	0.13	0.45	6.7	0.14	0.50
	22S Dark Gray	6.7	0.14	0.50	6.7	0.15	0.55	7.3	0.16	0.57	7.9	0.17	0.61
	26S Dark Orange	7.3	0.16	0.60	7.3	0.18	0.64	7.9	0.20	0.70	7.9	0.20	0.73
	30S Light Green	9.1	0.19	0.68	9.1	0.20	0.70	9.8	0.20	0.73	9.8	0.21	0.77
	36S Brown	10.4	0.23	0.82	10.4	0.24	0.86	10.4	0.26	0.95	11.0	0.28	1.00
HIGH FLOW	18M Ivory	6.1	0.25	0.91	6.1	0.26	0.95	6.7	0.28	1.00	7.3	0.30	1.07
	26M Medium Orange	7.3	0.35	1.27	7.3	0.38	1.36	7.9	0.41	1.48	7.9	0.44	1.57
	30M Green	9.1	0.36	1.30	9.1	0.39	1.41	9.8	0.42	1.50	9.8	0.45	1.61
	36M Light Brown	10.4	0.45	1.61	10.4	0.49	1.77	10.4	0.53	1.91	11.0	0.56	2.02
LONG THROW	40 Orange	12.2	0.13	0.48	12.2	0.15	0.52	12.8	0.15	0.55	12.8	0.16	0.57
	44 Red	13.4	0.22	0.80	14.0	0.23	0.82	14.0	0.26	0.93	14.0	0.27	0.98
	48 Blue	14.6	0.37	1.32	14.6	0.40	1.45	14.6	0.43	1.55	14.6	0.44	1.60
	54 Beige	15.2*	0.78*	2.82*	16.5*	0.85*	3.07*	17.1*	0.92*	3.32*	17.1*	0.98*	3.52*

\*For best results, recommended for use in triangular spacing only.

†Matched precipitation nozzles.

Data reflects no pressure regulation. For a black rotor, it is the pressure at the inlet to the rotor casing after the pressure had been regulated through a valve. All data is generated from tests conducted in accordance with ASAE Standard S398.1 for at least 30 minutes, in zero-wind conditions. Rain Bird recommends the use of SPACE for Windows® equivalent programming or derived performance data to optimize nozzle selection.

\*\*Nozzle Shipping: (Standard Nozzle Installed/Included Smaller and Larger Nozzles): 22S/18S, 26S 30S/26S, 36S 30M/18M; 26M; 36M 36S/40, 44 48/44, 54

GOLF ROTOR STATOR CONFIGURATION					
NOZZLE	PRESSURE SETTINGS PSI (BARS)				ALL SAM/HYD AND BLOCK
	60 (4,1)	70 (4,8)	80 (5,5)	100 (6,9)	
<b>500/550</b>					
Beige #52	S4	S4	S4	S4	S4
Gray #53	S4	S4	S4	S4	S4
Red #54	S8	S8	S8	S8	S8
<b>700</b>					
White #28	SPC	SPC	SPC	SPC	SPC
Blue #32	SPO	SPO	SPO	SPO	SPO
Yellow #36	SPO	SPO	SPO	SPO	SPO
Orange #40	SNP	SNP	SNP	SNP	SNP
Green #44	SNP	SNP	SNP	SNP	SNP
Black #48	N/R	SNP	SNP	SPR	SNP
<b>751</b>					
White #28	SPC	SPC	SPC	SPC	SPC
Blue #32	SPO	SPO	SPO	SPO	SPO
Yellow #36	SPO	SPO	SPO	SPO	SPO
Orange #40	SNP	SNP	SNP	SNP	SNP
Green #44	SNP	SNP	SNP	SNP	SNP
Black #48	SNP	SPR	SPR	SPR	SNP
<b>900</b>					
Blue #44	SPC	SPC	SPC	SPC	SPC
Yellow #48	SPC	SPC	SPC	SPC	SPC
Orange #52	SPC	SPO	SPO	SPO	SPO
Green #56	N/R	SNP	SNP	SNP	SNP
Black #60	N/R	SNP	SPR	SPR	SPR
Brown #64	N/R	SPR	SPR	SPR	SPR
<b>950</b>					
White #18C	SPC	SPC	SPC	SPC	SPC
Gray #20C	SPC	SPC	SPC	SPC	SPC
Blue #22C	SPC	SPC	SPC	SPC	SPC
Yellow #24C	SPC	SPC	SPO	SPO	SPO
Orange #26	SPO	SPO	SPO	SPO	SPO
Green #28	N/R	SNP	SPR	SPR	SPR
Black #30	N/R	SNP	SPR	SPR	SPR
Brown #32	N/R	SNP	SPR	SPR	SPR

SPC = Stator Poppet Closed  
 SPO = Stator Poppet Open  
 SNP = Stator No Poppet  
 SPR = Spacer  
 SO = Screen Only  
 S4 = Stator with 4 holes  
 S8 = Stator with 8 holes  
 N/R = Not a recommended pressure and nozzle combination

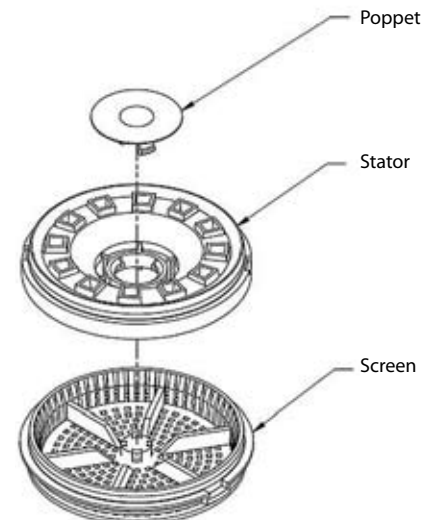

Looking to enhance the performance of your golf course irrigation system? Rain Bird® Swing Joints are the perfect solution. Featuring superior flow characteristics and excellent structural integrity, these swing joints are designed to deliver the performance you expect from Rain Bird while saving you money. They are available in a wide range of configurations. Rain Bird Swing Joints are the perfect complement to our Golf Series Rotors.

### SPECIFICATIONS

**Diameters:** 1" (2.5 cm), 1.25" (3.2 cm) and 1.5" (3.8 cm)

**Lengths:** 8" (20.3 cm), 12" (30.5 cm) and 18" (45.7 cm)

**Inlet Type:** NPT, BSP, ACME, spigot and socket

**Outlet Thread Type:** NPT, BSP or ACME

#### Enlarging NPT, BSP or ACME Outlets:

Available on 1" (2.5 cm) and 1.25" (3.2 cm) swing joints for connections to many rotors with 1 1/4" (3.2 cm) and 1 1/2" (3.8 cm) inlet sizes respectively (no additional adapters required)

**Outlet Configuration:** Single-top or triple-top

**Pressure Rating:** 315 psi (21.7 bar) at 73°F (22.8°C)

**Reducing ACME Inlet:** Available on 1 1/4" (3.2 cm) diameter swing joints for connection to a 1 1/2" ACME service tee

**Multiple Inlet/Outlet Configurations:** Available with standard and triple top configurations for added rotor positioning flexibility. Also available are models for top mount or side mount to lateral lines.

- **Superior Flow Characteristics.** An innovative swept elbow design\* reduces pressure loss by 50 percent over other swing joints.
- **Excellent Structural Integrity.** Reduces the costs associated with fatigue-related failures.
- **Double O-ring Protection.** Provides a better seal to ensure that joints are kept clean and can be repositioned easily.
- **Modified ACME Outlet.** Improves safety by losing seal engagement before losing thread engagement during rotor removal.
- **Color-coding and Distinct Size Markings.** Reduce costs by eliminating errors and improving installation efficiency with quick size identification at the job site.
- **Oversized Threaded Inlets.** Make hand-tightening and blind installations (underwater) easier. This also reduces the risk of potential damage caused by over-tightening with a wrench.
- **Extended Warranty.** When used with Rain Bird Golf Rotors, extends rotor and swing joint warranty to five years.

\*Patent pending

### NOW AVAILABLE

#### NPT and BSP ACME Adapters

If you currently have NPT or BSP Swing Joints, you can now enjoy the benefits of ACME-threaded rotors by utilizing a Rain Bird® NPT-ACME or BSP-ACME side of the adapter. Just screw the adapter into the inlet on the ACME case, and then screw the rotor with the adapter onto the NPT or BSP swing joint until it is snug. Available for 1", 1 1/4", and 1 1/2" swing joints, the adapter adds only about 1 3/8" to the installed height of the rotor, and is rated at the same operating pressures as Rain Bird® Swing Joints.



● NPT or BSP to ACME Adapter

1 1/2" ACME Outlet

Lay Arm

1 1/2" ACME Inlet

\*Enlarging outlet available only on 1" and 1 1/4" diameter models

\*\*Reducing inlet available on 1 1/4" diameter models

### ● Swing Joints

## HOW TO SPECIFY

